



CONTENTS:

- A PRAYER TO JAGANNATH'S CART WHEEL

Click here to read this complete issue or other back issues of Bindu.

A PRAYER TO JAGANNATH'S CART WHEEL

The following verse is composed in the style known as citra-kāvya, which literally means, “picture-poem”. In this gender of Sanskrit poetry, which goes back at least 2,000 years, the verses are designed to be read in the form of a picture. When the reader lays out the syllables or sometimes words, in the shape of the given picture, hidden meanings are found. Those who have some expertise in Sanskrit may find some surprises in the below contemporary verse, not all of which are to be found in the translation. Perhaps the most famous example of this style of poetry is Srila Rupa Goswami’s Citra-kavitvāni from his book Stava-māla. However there are examples of this style to be found in the literary traditions of Odisha, South India, and other places on the Indian subcontinent. The following verse is in a sub-style of citra-kāvya, known as a cakra-bandha, or shape of a wheel.

*bhavyam hanta ca kṛṣṇa-yāna-suyutam cedam supārṣad sadā
kratvā riṣṭa yutandadāti suvaram naḥ ca pramode 'kṣaye
viprāḥ pārśvam umiñjayanti sudi yac cakram sumānanti uta
tac cakram bhava-cakram āśu viramed āmuktaye me 'cyuta*

Synonyms: *bhavyam* — full of grandeur; *hanta* — how wonderful!; *ca* — and; *kṛṣṇa-yāna-suyutam* — situated so beautifully in Krishna’s cart; *cedam* — and it is; *supārṣad* — loyal associate; *sadā* — eternally; *kratvā* — by its activity of moving around; *riṣṭa-yutam* — which is auspicious; *dadāti* — it bestows; *suvaram* — benedictions; *naḥ* — for our; *ca* — and; *pramode* — joy; *akṣaye* — unlimited; *viprāḥ* — devotee Brahmins; *pārśvam* — around it; *u-miñjayanti* — sing its glories; *sudi* — on the occasion of the ratha-yātrā festival in the bright fortnight of the Āṣāḍha month; *yac cakram* — to the cart-wheel; *sumānanti uta* — or pay their respects; *tac cakram* — may that cart-wheel; *bhava-cakram* — cycle of birth and death; *āśu viramed* — stop quickly; *āmuktaye* — for

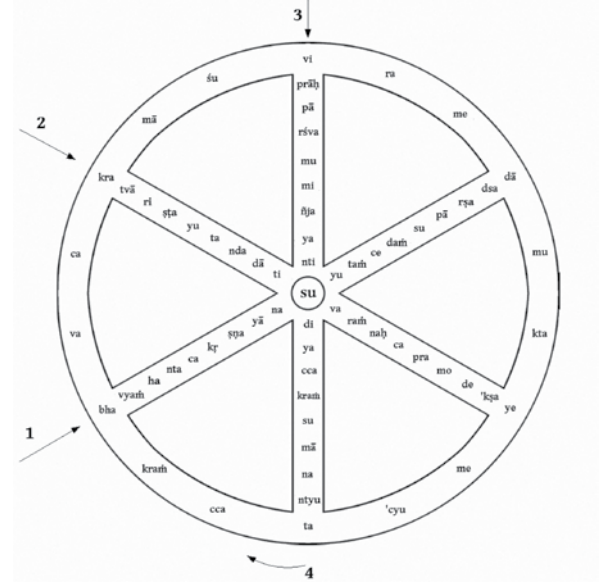

Wheel diagram for the verse

the purpose of bestowing liberation; *me* — my; *acyuta* — O Achyuta [Jagannath]!;

Sanskrit Explanation: *hanteti* harṣe. *cakramidaṁ bhavyam tathā cedam cakram “kṛṣṇa-yāna-suyutam”* arthāḥ jagannātha-devasya rathe suṣṭhu sthitam. *tathā cedam cakram jagannātha-devasya “supārṣad-sadā”* arthān nitya-pārṣad-rūpeṇa sthitam. *tathedaṁ cakram “kratvā”* arthād bhramaṇa-karmaṇā. *kratvā karmaṇā iti ṛg-veda-bhāṣye sāyaṇācāryaḥ*. *bhramaṇa-karmaṇā cedam cakram riṣṭa-yutam* maṅgala-yutam *su-varam* suṣṭhu varam *naḥ dadāti*. *kena hetunā dadāti? asmākam “akṣaye pramode”* arthād akṣaya-pramodāya eva dadāti. *nimittāt karma-yoge saptamīti vārttikena. “sudi”* arthād āṣāḍha-śukla-pakṣe rathayātrā-mahotsave yaccakrasya *pārśvam* samīpe *viprāḥ* arthād vaiṣṇava-brāhmaṇāḥ *umiñjayanti* stuvanti. *‘u’* iti pāda-pūraṇa-nipātaḥ. *uta* athavā te *viprāḥ yaccakram sumānanti* suṣṭhu rūpeṇa namanti *taccakram me bhava-cakram āśu viramed “ā”* samyak *muktaye* he *acyuta!* ṣaḍāra-cakre dāsābhāṣena hari-pārṣada-dāsenā *“haripārṣadena kṛtamidaṁ cakram”* iti sva-hastākṣaram sammiveṣitam. *tac ca rekhā-citre draṣṭavyaḥ*.

Translation: How wonderful! This wheel situated so beautifully in Krishna's cart appears full of grandeur. It is his eternal, loyal associate. By its activity of moving around, it bestows auspicious benedictions for enhancing our unlimited joy. On the occasion of the *ratha-yātrā* festival in the bright fortnight of the *Āṣāḍha* month, Brahmins and devotees around this wheel sing its glories or pay respects to it. O Lord Achyuta! May that cart wheel (*cakra*) stop the wheel of my birth and death (*bhava-cakra*) and bestow liberation. — HPD

SRI KRISHNA KATHAMRITA BINDU

A free bi-monthly service provided by:

Gopal Jiu Publications

c/o Sri Krishna Balarama Mandir

National Highway No. 5, IRC Village

Bhubaneswar, Orissa, India, 751015

Email: katha@gopaljiu.org

Website: www.gopaljiu.org

Subscriptions: minimag@gopaljiu.org

Gopal Jiu Publications is a branch of the International Society for Krishna Consciousness, Founder-Acharya: His Divine Grace A.C. Bhaktivedanta Swami Prabhupada.

Quotations from the books, letters, and lectures of His Divine Grace A. C. Bhaktivedanta Swami Prabhupada ©Bhaktivedanta Book Trust International. All other materials, unless specified, © ISKCON Bhubaneswar/Gopal Jiu Publications. All rights reserved. Blanket permission is given to redistribute Bindu in electronic or print form provided no changes are made to the contents.